



Guangzhou Best Electronic Technology co.,Ltd

www.entelechybattery.com

Address: 5/F, C District, No. 98, Road 9, Pacific Industrial Zone, Xintang Town, Zengcheng District, Guangzhou, China



BST-LRG BATTERY SPECIFICATION

Product type: LRG Battery

product model: BST-LRG-12.8V180Ah



Guangzhou Best Electronic Technology Co. ,Ltd

Amendment Records

Note: The company's electronic documents and printed documents with the red "Controlled Document" seal are controlled documents, and other printed documents are non-controlled documents.



1. 1.Scope of application

This specification describes the technical index requirements of 12.8V180Ah lithium iron phosphate battery.

2. Model: 12.8V180Ah

2.1 The battery uses a cylindrical cell model of 32700 lithium iron phosphate 3.2V6Ah.

2.2 The entire battery pack is composed of 30PCS cells in parallel to form a battery string, and 4 strings of cells are connected in series to form a battery module, a total of 120PCS cells;

3. Reference standards and test requirements

3.1 YD/T2344.1-2011 communication lithium iron phosphate battery pack

3.2 UN38.3 "Recommendation on the Transport of Dangerous Goods: Manual of Tests and Standards" Part III, Section 38.3

3.3 GB4208-2008/IEC60529:2001 Enclosure protection class (IP code)

3.4 GB/T 1804-2000 General tolerances Tolerances of linear and angular dimensions without tolerances

3.5 Standard test environment

Temperature: (25±2)°C

Humidity: (65±20)%RH

Standard charging current: 0.3C

Standard discharging current: 180A

4. Technical Parameters

4.1 System parameters

Project		Specification	Remarks
1	Rated voltage	12V	
2	Nominal capacity	180Ah	1C current discharging after normal charging
3	Nominal voltage	12.8V	During normal charging and discharging



4	Maximum continuous charging current	180A	1.0C
5	Maximum continuous discharging current	180A	1.0C
6	Max discharging current	300A	for 50ms
7	cycle life	2000 times	25°C±2°C ; 1.0C charging 1.0C discharging; 80%DOD;
8	Charging max voltage	14.6V	@(20-45)°C
9	End of discharging voltage	8.4V	Determining discharge cutoff voltage of capacity, single series cutoff voltage 2.5±0.05V
10	Charging time	3.5h	Rated charging current 0.3C
11	Charge-discharge efficiency	≥96%	Volumetric efficiency
12	Cooling way	Natural cooling	
13	Working temp	IP67	
14	discharging	charging	(0-60)°C
		Relative humidity	(-20-60)°C
15	Working temp	(65±20)%	
16	Battery pack composition	30parallel and 4 series	A total of 120PCS battery cells
17	Battery Pack Weight	≤24Kg	

4.2 BMS parameter

4.2.1 BMS function introduction

- Discharge over current protection function;
- Over voltage, under voltage, temperature and overload protection functions;
- Using an integrated solution, the performance of the protection board is more stable;
- Using contactor control, low internal resistance, high current, high precision;
- Using contactor control, low internal resistance, high current, high precision

Note: The company's electronic documents and printed documents with the red "Controlled Document" seal are controlled documents, and other printed documents are non-controlled documents.

4.2.2 BMS parameter

Voltage		8.4V~15.0V
Working current	Working range	≤100A
Working temp	Working range	-20℃ ~ +70℃
Consumption	Working consumption	≤50μA
Inpedance		<20mΩ
Over-charge protection	Protection voltage	3.75±0.05V
	Recover voltage	3.60±0.05V
	Over voltage protection delay	1000 mS
Over-discharge protection	Protection voltage	2.10±0.1V
	Recover voltage	2.3±0.1V
	Protection delay	200 mS
	Protection current	300A
Short-circuit protection	Production delay	100~300uS
	Recover condition	Disconnect load or charge
Temp protection	temp protection	85℃
	recover temp	60℃
Charge balance	Charge balance voltage	3.6±0.05V
	Charge balance current	25±5mA

4.2.3 Schematic of the PCB

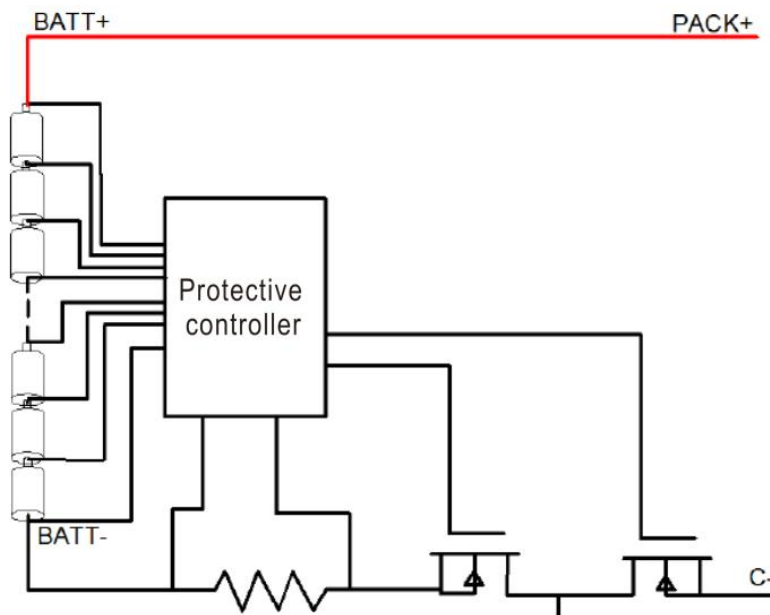

Note: The company's electronic documents and printed documents with the red "Controlled Document" seal are controlled documents, and other printed documents are non-controlled documents.

4. 3 Battery pack structure size

4.3.1 Battery bag outside picture (522*240*218mm without handle;
tolerance class: GB/T1804-M)



12V180Ah Battery outside picture

(Picture only for you reference, result depends on production)

5. Battery function

5.1 Cycle Function

Project		Standard	Test Condition
1	Cycle lifespan	After 2000 cycles, the remaining capacity is $\geq 80\%$ of the rated capacity	In a 25°C environment, charge and discharge with 1c Current 80% dod

5. 2 High and low temperature performance

Project		Standard	Test Condition
1	-20°C low temperature discharge	Discharge capacity $\geq 70\%*$ rated capacity	After standard charging, in an environment of $-20^{\circ}\text{C} \pm 2^{\circ}\text{C}$, let it stand for 20h discharge to the cut-off voltage at a constant current of 0.8C

Note: The company's electronic documents and printed documents with the red "Controlled Document" seal are controlled documents, and other printed documents are non-controlled documents.



2	55°C High temperature discharge	Discharge capacity ≥ 95%* rated capacity	After standard charging, let stand for 5h at 55°C±2°C, discharge to cut-off voltage at 0.8C constant current
---	---------------------------------	--	--

5. Battery function

5.1 Cycle Function

Project		Initial SOC	Standard	Condition	
1	Capacity retention rate	25 °C 1month	100%	90%	The percentage of the discharge capacity after storage to the capacity before storage, test condition: standard charge and discharge
		60°C 7day	100%		
2	Capacity recovery rate	25 °C 1month	100%	95%	After testing the remaining capacity after storage, charge and discharge as standard Power cycle 3 times, the highest capacity is the recovery capacity, the percentage of the recovery capacity and the capacity before storage is the recovery rate
		60°C 7day	100%		

6. Storage and transportation

6.1 According to the characteristics of the battery, the lithium iron phosphate battery pack should meet its storage environmental conditions during storage and transportation, so as to protect the battery performance to the utmost.

6.2 Appropriate protection should be provided during storage and transportation of lithium iron phosphate batteries; Maintain a SOC level of about 50%; ensure that no short circuit and liquid enter the lithium iron phosphate battery or soak in liquid (such as water, oil, etc.);

Note: The company's electronic documents and printed documents with the red "Controlled Document" seal are controlled documents, and other printed documents are non-controlled documents.



6.3 If not in use temporarily, the battery should be stored in a dry, clean and well-ventilated warehouse at 0°C ~ 45°C.

6.4 During the process of loading and unloading, the battery should be handled with care, and avoid dropping, rolling, and heavy pressure.

7. Safety rules

Misuse of lithium-ion rechargeable batteries may cause battery damage or personal injury.

Before using the lithium-ion rechargeable battery, please read the following safety rules carefully

7.1 Battery precautions

7.1.1 Do not expose the battery to extreme heat or fire.

7.1.2 Do not short-circuit, overcharge or over-discharge the battery.

7.1.3 Do not subject the battery to excessive mechanical shock.

7.1.4 Do not immerse the battery in sea water or water, or make it damp.

7.1.5 Do not disassemble or repair the battery.

7.1.6 Do not put the battery and metal objects such as necklaces, coins or hairpins together.

7.1.7 Do not cause obvious damage or deformation of the battery.

7.1.8 Do not connect the battery directly to the socket.

7.1.9 Do not mix lithium-ion batteries.

7.1.10 Do not place the battery in direct sunlight.

7.1.11 Keep the battery away from children.

7.1.12 Do not puncture, beat or trample the battery.

7.2 Battery instructions

7.2.1 Charging

1) The battery charging temperature range is (0-60)°C.

2) Use a constant current and constant voltage lithium-ion battery charger.



- 3) Correctly connect the positive and negative poles of the battery, and reverse charging is strictly prohibited. If the positive and negative poles of the battery are reversed, there is a risk of arcing and short circuit.

7.2.2 Discharge

- 1) The discharge temperature range of the battery is (-20-60)°C.
- 2) During the long period of non-use of the battery, the battery may be in a certain over-discharged state due to its self-discharge characteristics. In order to prevent the occurrence of over-discharge, the battery should be charged regularly to maintain its cell voltage between (3.3-3.5)V. Over-discharge will cause the loss of battery performance and function.